

UDC 631.356.02

MATHEMATICAL MODEL OF THE MOVEMENT OF A TOWED MACHINE FOR CLEANING BEET TOPS RESIDUES FROM ROOT CROP HEADS

V. M. Bulgakov ¹, V. V. Adamchuk ², I. V. Holovach ¹, Ye. I. Ihnatiev ³

¹ National University of Life and Environmental Sciences of Ukraine
15, Heroyiv Oborony Str., Kyiv, Ukraine, 03041

² National Scientific Center "Institute for Agricultural Engineering and Electrification" NAAS of Ukraine
11, Vokzalna Str, vil. Hlevakha-1, Vasylkivsky District, Kyiv Region, Ukraine, 08631

³ Tavria State Agrotechnological University
18, B. Khmelnytskoho prov., Melitopol, Zaporizhzhia Region, Ukraine, 72310

E-mail: vbulgakov@meta.ua

Received on January 10, 2017

The work of a tractor-towed machine for cleaning beet top residues from root crop heads, when used with supporting pneumatic wheels, is accompanied with its oscillations in the vertical plane, which has considerable impact on the quality of implementing the technological process. Therefore, the determination of optimal parameters for the cleaning machine, ensuring more stable movement of its cleaning working tool, in the longitudinal-vertical plane first and foremost, is an important task of the mechanization of sugar beet growing industry. **Aim.** To enhance the efficiency of cleaning sugar beet top residues from root crop heads via the elaboration of the mathematical model of the oscillating movement of the towed machine for cleaning beet top residues from root crop heads in the longitudinal-vertical plane. **Methods.** The methods of building computational mathematical models for the functioning of agricultural machines and equipment, based on theoretical mechanics and advanced mathematics, were used. **Results.** The elaborated equivalent scheme of the movement of the towed cleaning machine was used to obtain the system of two non-linear differential equations for detailed study of the oscillations of the root crop head cleaner in the longitudinal-vertical plane while its supporting pneumatic wheels are moving along uneven soil surface. The mathematical model for the movement of the cleaner with horizontal cleaning roller, elaborated on the basis of initial dynamics equations in the Lagrangian form of the second kind, allowed determining the connection between constructive and kinematic parameters of the vehicle and its oscillating characteristics. The established dependencies formed the prerequisites for further mathematical digital modelling of the parameters of the towed machine for cleaning of root crop heads with a horizontal cleaning roller. **Conclusions.** The established computational model allows optimizing the values of several parameters, characterizing the oscillations of the machine in the longitudinal-vertical plane.

Keywords: sugar beet, beet top harvesting, tractor, oscillations, differential equations.

DOI: 10.15407/agrisp4.01.003

INTRODUCTION

When the machine for cleaning beet top residues from root crop heads is towed onto the rear of the tractor, its spatial movements are determined by the translational velocity of the tractor movement, field surface texture, location of supporting wheels relative to the suspension system, *etc.*

The use of supporting pneumatic wheels conditions the oscillations of the cleaning machine in the vertical plane, which has more impact on the quality of implementing the technological process. Thus, let us further consider the movement of the cleaning machine only in the longitudinal-vertical plane, i.e. build the mathematical model of experimental machine oscillations during its movement along uneven soil surface.

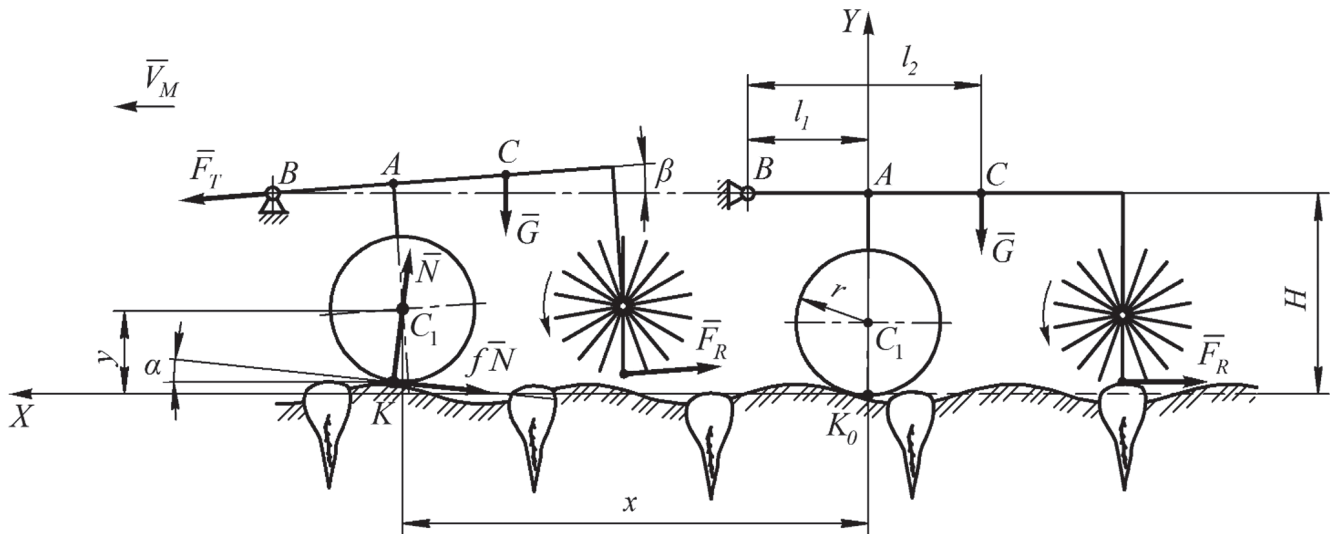

Fig. 1. Equivalent scheme of the cleaning machine movement along uneven soil surface

The use of the cleaner of improved design, towed onto the rear of the tractor to clean sugar beet heads, causes its free oscillating spatial movements. The analytical definition of conditions, when the mentioned oscillating movements will promote the improvement of the technological process of cleaning beet top residues from sugar beet heads, is a relevant task of the mechanization of sugar beet industry.

It is an urgent issue of the mechanization of sugar beet growing to clean beet top residues from root crop heads after the main cutting off the root using the cutting tools of beet top harvesting machines. The relevance of this issue is confirmed by several scientific works, dedicated to the study of the constructions of root crop head cleaners [1–4]. They present the results of theoretical and experimental studies of sugar beet head cleaners of different designs: spade-shaped, ring, sector, drum types as well as the cleaner in the shape of paraboloid. However, the mentioned works pay insufficient attention to the study of the impact of the oscillations of spade-shaped cleaners with horizontal drive shafts on the movement of its working tools. This problem is yet to be disclosed in the scientific literature. Therefore, the studies, which would allow estimating the impact of oscillations, caused by the movement of the cleaner with the horizontal working roller along uneven soil surface, on the quality of cleaning beet top residues from root crop heads, are relevant.

For instance, the well-known method [5] may be used to build the computational mathematical model of this machine, which would allow analyzing the impact of its constructive parameters on the working movement

along the rows of sugar beets on condition of uneven soil surface.

Thus, the study of the movement of root crop cleaner and the impact of its oscillations in the longitudinal-vertical plane on the quality of implementing the technological process require deeper investigations and substantiation of constructive and kinematic parameters, which will ensure high efficiency of cleaning root crop heads.

The aim of the study was to create the mathematical model of the oscillating movement of the machine for cleaning beet top residues from root crop heads, towed onto the rear part of the tractor, in the longitudinal-vertical plane.

MATERIALS AND METHODS

The methods of building computational mathematical models for the functioning of agricultural machines and equipment, based on theoretical mechanics and advanced mathematics, were used in the theoretical research.

RESULTS AND DISCUSSION

Let us build an equivalent scheme of the movement of the rear-towed cleaning machine in the longitudinal-vertical plane, which forms a united aggregate with the tractor (Fig. 1).

Here let us consider the movement of one supporting wheel with the radius of r , deeming the other one to be in the same state. Let us suppose that during the copying process the supporting wheel, moving along the sugar beet inter-row spacing on the soil surface of

sinusoidal lateral section [6], shifted from one position into another. In the rotation plane the supporting wheel is under the impact of the gravity force of the machine \overline{G} and the towing force \overline{F}_T . From the side of the root crop cleaner there is resistance force \overline{F}_R , equal in its value and opposite in the direction to the force \overline{Q} of cutting the beet top off the head.

The effect of the mentioned forces in the contact point for K the supporting wheel and uneven soil surface is the formation of normal \overline{N} and tangent $f\overline{N}$ reactions (where f – coefficient of rolling resistance) [7]. The directions of the action of normal \overline{N} and tangent $f\overline{N}$ reactions are determined by the angle α .

The angle between the towing force \overline{F}_T and the direction of aggregate movement is marked as β , which conditions the character of vertical oscillations of the cleaning machine in the longitudinal-vertical plane. The center of the cleaning machine frame suspension onto the tractor shall be defined as B , the height of the frame suspension – as H . Let us assume that the joint B does not move in the vertical plane, i.e. the process of copying occurs only due to the supporting wheels of the cleaner. Let us deem the translational movement of the cleaning machine to be constant and define it as \overline{V}_M .

Let us refer the mentioned system to immovable Cartesian coordinates XK_0Y [8], assuming that all its points move only in this plane. Let us locate the center of coordinate axes in the point K_0 of the supporting wheel contacting soil, and consider it to be the reference point. Evidently, any other point of the supporting wheel contacting soil may be accepted as the reference point. Let us direct the axis K_0X horizontally along the aggregate movement (in the direction of the velocity vector \overline{V}_M), and the axis K_0Y – vertically upwards. As seen from the data in Fig. 1, the location of the supporting wheel center (the point C_1) is defined by coordinates x and y .

Let us consider the movement of the point of suspending the cleaner to the tractor in the first approximation (point B) to be linear and steady [9]. Here the gravity center of the machine (point C) is at the distance of l_2 from the suspension point. The distance between the suspension axis of the cleaning machine (point B) and the suspension axis for supporting wheels (point A) shall be defined as l_1 .

The mass of the whole cleaning machine shall be defined as M , the mass of the supporting wheels – as m , and $m = m_1 + m_2$ (m_1 – the mass of the first wheel, m_2 – the mass of the second wheel). The gravity force \overline{G} of the cleaning machine shall be deemed as applied in

its gravity center (point C). The mass of the supporting wheels shall be concentrated in point C_1 .

Pneumatic supporting wheels shall be presented as springy damping models with the coefficient of rigidity c and the coefficient of damping μ [10]. As there are two supporting wheels, let us double the mentioned coefficients. Let us consider that in the general case, while moving, the supporting wheels crumple the upper layer of soil surface, move along uneven soil surface of the sinusoidal profile, which changes according to the law [6]:

$$y = h \left[1 + \sin \left(kx - \frac{\pi}{2} \right) \right], \quad (1)$$

where y – the current ordinate of the height of soil surface irregularity, m; h – half of the height of soil surface irregularity, m; k – frequency of cycles of occurrence of soil surface irregularities, m^{-1} ; $x = V_M t$ – the value of the current horizontal plane, m; V_M – the velocity of cleaning machine movement, $m \cdot s^{-1}$.

In the first approximation let us consider that the supporting wheel of the cleaning machine contacts with the field surface irregularity in the point K , which belongs to the sinusoid (1).

As, due to springy properties, the center of mass of pneumatic supporting wheels makes independent oscillating movements (point C_1) and the ordinates of the heights of soil surface irregularity y have much lower values of the movement of the machine x , let us assume that these oscillations are defined by the independent coordinate y .

Here the positions of the center of mass of the machine (point C) in the longitudinal-vertical plane are completely conditioned by the independent coordinate β , i.e. the angle between the machine frame and the horizon. Therefore, the considered oscillating system has two freeness degrees and its movement is completely defined by two independent generalized coordinates: $q_1 = \beta$ and $q_2 = y$, which shall be further used for differential equations of the movement of the cleaning machine in the longitudinal-vertical plane.

Here the velocity V of the movement of the center of mass of the supporting wheels equals:

$$V = \sqrt{\dot{x}^2 + \dot{y}^2}. \quad (2)$$

Taking into consideration that $x = V_M t$, it shall be as follows:

$$V = \sqrt{V_M^2 + \dot{y}^2}, \quad (3)$$

where V_M – the velocity of the translational movement of the cleaning machine, $\text{m}\cdot\text{s}^{-1}$.

The determination of kinetic energy of this dynamic system also requires establishing the angular rate of the supporting wheel and presenting it via the known parameters. This can be done as follows:

$$\omega = \frac{dS}{dt} \cdot \frac{1}{r}, \quad (4)$$

where ω – the angular rate of the supporting wheel, $\text{rad}\cdot\text{s}^{-1}$; S – the value of the radial movement of the supporting wheel along the sinusoidal profile of the soil surface, m ; r – wheel radius, m .

Here the differential of the arc of the supporting wheel shifting equals:

$$dS = \sqrt{dx^2 + dy^2} = \sqrt{1 + h^2 k^2 \cos^2\left(kx - \frac{\pi}{2}\right)} dx, \quad (5)$$

or

$$dS = \sqrt{1 + h^2 k^2 \cos^2\left(kV_M t - \frac{\pi}{2}\right)} \cdot V_M dt. \quad (6)$$

Setting the value (6) into (4), we shall obtain the value of the required angular rate ω . It is:

$$\omega = \frac{\sqrt{1 + h^2 k^2 \cos^2\left(kV_M t - \frac{\pi}{2}\right)} \cdot V_M}{r}. \quad (7)$$

To build differential equations of the movement of the oscillation system under consideration, let us use the initial equations in the Lagrangian form of the second kind as follows [7]:

$$\frac{d}{dt}\left(\frac{\partial T}{\partial \dot{q}_i}\right) - \frac{\partial T}{\partial q_i} = Q_i - \frac{\partial P}{\partial q_i} - \frac{\partial R}{\partial \dot{q}_i}, \quad (8)$$

where T – kinetic energy of the dynamic system; P – potential energy of the system; Q_i – the summarized force; R – dissipation function.

Let us define the components of the equation (8). The kinetic energy of the dynamic system is:

$$T = T_1 + T_2 + T_3 + T_4, \quad (9)$$

where T_1 – kinetic energy of the translational motion of the cleaning machine (its center of gravity); T_2 – kinetic energy of the oscillating motion of the machine frame around the point B ; T_3 – kinetic energy of the rotational motion of the supporting wheels around its axes; T_4 – kinetic energy of the vertical oscillations of the supporting wheels due to the springy-ductile resistance of their pneumatic tires.

In their turn, the components of kinetic energy are as follows:

$$T_1 = \frac{MV_M^2}{2} \quad (10)$$

where M – the mass of the cleaning machine, kg ; V_M – the velocity of the translational motion of the center of mass of the cleaning machine, $\text{m}\cdot\text{s}^{-1}$.

$$T_2 = \frac{I_B \dot{\beta}^2}{2} \quad (11)$$

where I_B – inertia moment of the cleaning machine frame relative to the axis, perpendicular to the longitudinal-vertical plane and crossing the point B , $\text{kg}\cdot\text{m}^2$; $\dot{\beta}$ – angular rate of the machine frame rotation, s^{-1} .

$$T_3 = \frac{I_k \omega^2}{2} = \frac{I}{2r^2} I_k V_M^2 [1 + h^2 k^2 \sin^2(kx)], \quad (12)$$

where I_k – inertia moment of both supporting wheels relative to their axes of rotation, $\text{kg}\cdot\text{m}^2$; ω – angular rate of the rotation of the supporting wheel, s^{-1} .

$$T_4 = \frac{m \dot{y}^2}{2}, \quad (13)$$

where m – mass of both supporting wheels, kg ; \dot{y} – velocity of vertical oscillations of the supporting wheels, $\text{m}\cdot\text{s}^{-1}$.

Thus the equation (9) with the consideration of (10)–(13) shall be as follows:

$$T = \frac{MV_M^2}{2} + \frac{I_B \dot{\beta}^2}{2} + \frac{I_k \omega^2}{2} + \frac{m \dot{y}^2}{2}. \quad (14)$$

The potential energy P of the system shall be defined as follows:

$$P = c(l_1 \beta - y)^2 \quad (15)$$

where c – coefficient of rigidity of pneumatic supporting tires, $\text{N}\cdot\text{m}^{-1}$; l_1 – distance from the suspension axis of the machine to the axis of the supporting wheels, m .

The dissipative function R of this dynamic system shall be as follows:

$$R = \mu(l_1 \dot{\beta} - \dot{y})^2 \quad (16)$$

where μ – coefficient of damping of the supporting wheels, $\text{N}\cdot\text{s}\cdot\text{m}^{-1}$;

Let us find the summarized forces Q using the summarized coordinates β and y , which are a part of the right side of the Lagrangian equation of the second kind (8). Here Fig. 2 presents the location of the cleaning machine in a random point K_2 of the contact of the supporting wheel and soil, which allows demonstrating the change in the position of the machine frame while the supporting wheel moves from some contact point K_1 into point K_2 .

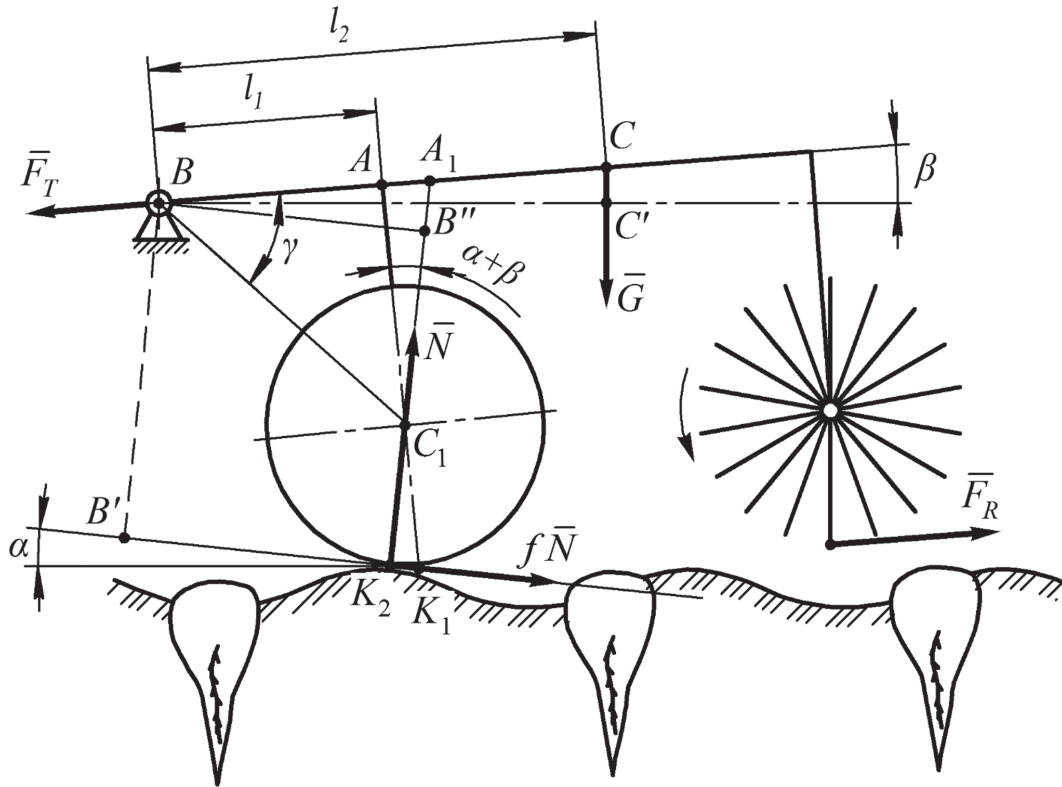

Fig. 2. Equivalent scheme of the cleaning machine movement at the moment of tripping over soil surface irregularity

To determine the summarized force Q_y using an independent coordinate y the equation of the elementary effect of forces on the possible shifting was used δy :

$$\delta W_y = \sum_{i=1}^n Q_y \cdot \delta q_y = -G \cdot \delta y - fN \sin \alpha \cdot \delta y + F_R \sin \beta \cdot \delta y + N \cos \alpha \cdot \delta y - F_T \sin \beta \cdot \delta y \quad (17)$$

It is noteworthy that normal \bar{N} and tangent $f\bar{N}$ reactions of soil on the supporting wheel have elementary effect on soil deformation and overcoming friction, respectively, i.e. they are relatively active forces.

Thus, the summarized force Q_y is as follows:

$$Q_y = \frac{\delta W_y}{\delta y} = -G - fN \sin \alpha + F_R \sin \beta + N \cos \alpha - F_T \sin \beta \quad (18)$$

To determine the summarized force Q_β using an independent angular coordinate β let us use the equation of the elementary effect of forces on the possible shifting $\delta \beta$. Thus,

$$\delta W_\beta = N \cdot BB'' \cdot \delta \beta + fN \cdot BB' \cdot \delta \beta + F_R \cdot H \cdot \delta \beta - G \cdot BC' \cdot \delta \beta, \quad (19)$$

where BB'' , BB' , BC' – arms of forces N , fN , G relative to point B according to Fig. 2.

The equation (19) shall be used to determine the value of the summarized force using the angular coordinate β , which equals:

$$Q_\beta = \frac{\delta W_\beta}{\delta \beta} = N \cdot BB'' + fN \cdot BB' + F_R \cdot H - G \cdot BC'. \quad (20)$$

Therefore, in this case the summarized force Q_β is the algebraic sum of moments of all the forces, acting upon this dynamic system relative to its point B .

Let us define the arms of forces in the equation (20), using the data in Fig. 2. According to the Figure, we shall obtain:

$$BB'' = l_1 \cos(\alpha + \beta) + (H - r) \cdot \sin(\alpha + \beta), \quad (21)$$

where α – the angle of between the tangent line and the sinusoid (1).

It is known that the slope of the curve $y = f(x)$ in this point equals the derivative from the equation for this curve by the variable x in this point, i.e. $\text{tg} \alpha = y'_x$. Taking (1) into consideration, we shall have:

$$y'_x = hk \cos(kx - \frac{\pi}{2}). \quad (22)$$

Thus,

$$\alpha = \arctg[hk \cos(kx - \frac{\pi}{2})]. \quad (23)$$

Then, according to Figure 2,

$$BB' = r + \cos(90^\circ + \alpha + \beta - \gamma) \sqrt{(H - r)^2 + l_1^2}. \quad (24)$$

Here

$$\text{tg} \gamma = \frac{AC_1}{AB} = \frac{H - r}{l_1}, \quad (25)$$

so

$$\gamma = \arctg \frac{H-r}{l_1}. \quad (26)$$

Using the triangle BCC' , we shall have:

$$BC' = l_2 \cos \beta. \quad (27)$$

Setting the obtained equations (21), (24) and (27) in the equation (20), we shall obtain the value of the summarized force Q_β using the coordinate β :

$$Q_\beta = N[l_1 \cos(\alpha + \beta) + (H-r) \cdot \sin(\alpha + \beta)] + fN[r + \cos(90^\circ + \alpha + \beta - \gamma) \sqrt{(H-r)^2 + l_1^2}] + F_R \cdot H - Gl_2 \cos \beta. \quad (28)$$

Having determined further required partial derivatives from kinetic energy T of this dynamic system, potential energy P , dissipative function R and setting these values of the summarized forces Q_y and Q_β into the initial Lagrangian equations of the second kind (8), we shall obtain the final system of differential equations:

$$\left. \begin{aligned} I_b \ddot{\beta} &= N[l_1 \cos(\alpha + \beta) + (H-r) \cdot \sin(\alpha + \beta)] + \\ &+ fN[r + \cos(90^\circ + \alpha + \beta - \gamma) \sqrt{(H-r)^2 + l_1^2}] + \\ &+ F_R \cdot H - Gl_2 \cos \beta - 2cl_1(l_1 \dot{\beta} - \dot{y}) - 2\mu l_1(l_1 \dot{\beta} - \dot{y}), \\ m \ddot{y} &= -G - fN \sin \alpha + F_R \sin \beta + N \cos \alpha - F_r \sin \beta + \\ &+ 2c(l_1 \dot{\beta} - \dot{y}) + 2\mu(l_1 \dot{\beta} - \dot{y}). \end{aligned} \right\} \quad (29)$$

Hereby, we shall have:

$$\left. \begin{aligned} \ddot{\beta} &= \frac{N[l_1 \cos(\alpha + \beta) + (H-r) \cdot \sin(\alpha + \beta)] +}{I_B} + \\ &+ \frac{fN[r + \cos(90^\circ + \alpha + \beta - \gamma) \sqrt{(H-r)^2 + l_1^2}]}{I_B} + \\ &+ \frac{F_R \cdot H - Gl_2 \cos \beta - 2cl_1(l_1 \dot{\beta} - \dot{y}) - 2\mu l_1(l_1 \dot{\beta} - \dot{y})}{I_B}, \\ \ddot{y} &= \frac{-G - fN \sin \alpha + F_R \sin \beta + N \cos \alpha - F_r \sin \beta}{m} + \\ &+ \frac{2c(l_1 \dot{\beta} - \dot{y}) + 2\mu(l_1 \dot{\beta} - \dot{y})}{m}. \end{aligned} \right\} \quad (30)$$

The obtained system (30) of two differential equations is a computational mathematical model of the movement of the tractor-towed machine for cleaning of beet top residues from root crop heads.

However, it was established that the mentioned system (30) includes some unknown variables – normal reaction \bar{N} , acting from the side of the soil onto the supporting wheel, and the force \bar{F}_R of resistance to the shifting of the cleaning working tool while implementing the technological process of cutting the beet top residues from sugar beet heads.

In the first approximation the unknown normal reaction \bar{N} can be defined on condition of the equilibrium

of the dynamic system, which is considered at a fixed moment in time [11], more specifically – on condition that the algebraic sum of moments of all the forces, acting upon the system relative to the point B , equals zero. Evidently, this equation may be obtained from (28) on condition of the equation $Q_\beta = 0$. As a result, we shall see that:

$$N[l_1 \cos(\alpha + \beta) + (H-r) \cdot \sin(\alpha + \beta)] + fN[r + \cos(90^\circ + \alpha + \beta - \gamma) \sqrt{(H-r)^2 + l_1^2}] + F_R \cdot H - Gl_2 \cos \beta = 0. \quad (31)$$

While determining the reaction N the unknown angle β in the first approximation may be considered rather small, which gives grounds to deeming it equal to zero.

In this case the equation (31) is as follows:

$$N[l_1 \cos \alpha + (H-r) \cdot \sin \alpha] + fN[r + \cos(90^\circ + \alpha - \gamma) \sqrt{(H-r)^2 + l_1^2}] + F_R \cdot H - Gl_2 = 0. \quad (32)$$

Using the equation (32), we shall determine the unknown reaction N . It shall be:

$$N = \frac{Gl_2 - F_R \cdot H}{l_1 \cos \alpha + (H-r) \cdot \sin \alpha + f[r + \cos(90^\circ + \alpha - \gamma) \sqrt{(H-r)^2 + l_1^2}]} \quad (33)$$

The equation (33) has been obtained for the case when the supporting wheel is at the random point of the sinusoidal profile of soil surface irregularities *i.e.* the sinusoid (1). If the supporting wheel is on even horizontal surface, *i.e.* directly on the axis OX , the equation (33) shall be simplified even more on condition of $\alpha = 0$ and shall equal:

$$N = \frac{Gl_2 - F_R \cdot H}{l_1 + f[r + \sin \gamma \sqrt{(H-r)^2 + l_1^2}]} \quad (34)$$

The value of the normal reaction, determined according to the equation (34) N may be used to solve the system of differential equations with the accuracy, sufficient for practice (30).

The force F_R of resistance of shifting the cleaning working tool along sugar beet head tops while implementing the process of cleaning them from top residues shall be determined on condition that its value equals the force of cutting one top [12], located on one head after the total cutting of the main bulk of top leaves, but with remaining short green and strong leaves.

The mentioned force of cutting one beet top at first, followed by average values of the number of tops, remaining on each root crop, with the consideration of physical and

mechanic properties of sugar beet plants was determined according to the data of the Institute of Bioenergy Crops and Sugar Beet, NAAS of Ukraine [13]. The value of the mentioned force of cutting, equal 100 N, was accepted for practical estimations. Thus, $F_R = 100\text{H}$ can be set into the system of differential equations (30).

To solve the system of differential equations (30), it is necessary to set constructive, kinematic, and force parameters, which are involved into the mentioned system of equations. First of all, one should determine the initial conditions which are satisfied using the initial variables. In this case these are

$$t = 0: y = 0, \dot{y} = 0, \beta = 0, \dot{\beta} = 0. \quad (35)$$

If specific values of constructive and kinematic parameters of the cleaning machine are used along with the values of its force parameters, which may be experimentally defined, there is a possibility of creating a program of digital computations and conducting digital modelling on PC which will allow changing the mentioned parameters to obtain the least values of the angle β and coordinates y , which characterize the oscillations of the cleaning machine in the longitudinal-vertical plane, and thus improving the technological process of cleaning beet top residues from root crop heads.

CONCLUSIONS

1. The elaborated equivalent scheme of the movement of the aggregate with the towed cleaning machine was used as a basis for obtaining the system of two non-linear differential equations, which allows modelling the oscillations of the cleaning roller regarding root crop heads in the longitudinal-vertical plane while pneumatic supporting wheels move along soil surface irregularities.

2. The computational mathematical model for the movement of the cleaner with horizontal cleaning roller, elaborated on the basis of initial dynamics equations in the Lagrangian form of the second kind, allowed determining the connection between constructive and kinematic parameters of the vehicle and its oscillating characteristics of the movement process.

3. Further mathematical modelling should be conducted using digital PC estimations of the parameters of a towed machine for cleaning of root crop heads with a horizontal cleaning roller, using the elaborated mathematical model on condition of optimizing the values for the angle β and coordinates y , which characterize machine oscillations in the longitudinal-vertical plane.

Математична модель руху причіпної очисної машини головок коренеплодів від залишків гички на корені

В. М. Булгаков¹, В. В. Адамчук²,
І. В. Головач¹, Є. І. Ігнат'єв³

E-mail:

¹ Національний університет біоресурсів і природокористування України

Вул. Героїв Оборони, 15, Київ, Україна, 03041

² Національний науковий центр "Інститут механізації і електрифікації сільського господарства" НААН України

Вул. Вокзальна, 11, Глеваха-1, Васильківський р-н, Київська обл., Україна, 08631

³ Таврійський державний

агротехнологічний університет

Пр. Б. Хмельницького, 18, Мелітополь, Запорізька обл., Україна, 72310

Робота агрегатованої з трактором машини для доочищення головок коренеплодів від залишків гички на корені в разі використання опорних пневматичних коліс супроводжується її коливаннями у вертикальній площині, що суттєво впливає на якість виконання технологічного процесу. Через це визначення оптимальних параметрів очищувальної машини, які забезпечуватимуть стабільніший рух її очищувального робочого органа, насамперед у повздовжньо-вертикальній площині, є важливим завданням галузі механізації буряківництва. **Мета.** Підвищення ефективності очищення головок коренеплодів цукрових буряків від залишків гички завдяки розробленню математичної моделі коливального руху причіпного очищувача головок коренеплодів від залишків гички у повздовжньо-вертикальній площині. **Методи.** Застосовано методи побудови розрахункових математичних моделей функціонування сільськогосподарських машин і машинних агрегатів на основі теоретичної механіки та вищої математики. **Результати.** Використовуючи розроблену еквівалентну схему руху причіпної очищувальної машини отримано систему двох нелінійних диференціальних рівнянь для детального дослідження коливань очисника головок коренеплодів у повздовжньо-вертикальній площині при русі його пневматичних опорних коліс по нерівностях поверхні ґрунту. Математична модель руху очисника з горизонтальним очисним валом, розроблена на основі вихідних рівнянь динаміки у формі Лагранжа II роду, дозволила встановити зв'язок між конструктивними і кінематичними параметрами машини та її коливальними характеристиками. Знайдені залежності створили передумови для подальшого математичного чисельного моделювання на ПК параметрів причіпного доочищувача головок коренеплодів з горизонтальним очисним валом. **Висновки.** Створена розрахункова модель дає можливість оптимізувати значення низки параметрів, які характеризують коливання машини в повздовжньо-вертикальній площині.

Ключові слова: цукровий буряк, збирання гички, трактор, коливання, диференційні рівняння.

Математическая модель движения прицепной очистительной машины головок корнеплодов от остатков ботвы на корню

В. М. Булгаков¹, В. В. Адамчук²,
И. В. Головач¹, Е. И. Игнатьев³

E-mail:

¹ Национальный университет биоресурсов и природопользования Украины
Ул. Героев Оборона, 15, Киев, Украина, 03041

² Национальный научный центр «Институт механизации и электрификации сельского хозяйства»
НААН Украины

Ул. Вокзальная, 11, Глеваха-1, Васильковский р-н,
Киевская обл., Украина, 08631

³ Таврический государственный
агротехнологический университет

Пр. Б. Хмельницкого, 18, Мелитополь,
Запорожская обл., Украина, 72310

Работа агрегатированной с трактором машины для доочистки головок корнеплодов от остатков ботвы на корню при использовании опорных пневматических колес сопровождается ее колебаниями в вертикальной плоскости, которые существенно влияют на качество выполнения технологического процесса. Поэтому определение оптимальных параметров очистительной машины, которые будут обеспечивать стабильное движение ее очистительного рабочего органа, прежде всего в продольно-вертикальной плоскости, является важной задачей области механизации свекловодства. **Цель.** Повышение эффективности очистки головок корнеплодов сахарной свеклы от остатков ботвы благодаря разработке математической модели колебательного движения прицепного очистителя головок корнеплодов от остатков ботвы в продольно-вертикальной плоскости. **Методы.** Применены методы построения расчетных математических моделей функционирования сельскохозяйственных машин и машинных агрегатов на основе теоретической механики и высшей математики. **Результаты.** С использованием разработанной эквивалентной схемы движения прицепной очистительной машины получена система двух нелинейных дифференциальных уравнений, примененная затем для детального исследования колебаний очистителя головок корнеплодов в продольно-вертикальной плоскости при движении его пневматических опорных колес по неровностям поверхности почвы. Математическая модель движения очистителя с горизонтальным очистительным валом, разработанная на основе исходных уравнений динамики в форме Лагранжа II рода, позволила установить

связь между конструктивными и кинематическими параметрами машины и ее колебательными характеристиками. Найденные зависимости создали предпосылки для дальнейшего математического численного моделирования на ПК параметров прицепного доочистителя головок корнеплодов с горизонтальным очистительным валом. **Выводы.** Созданная расчетная модель дает возможность оптимизировать значение ряда параметров, которые характеризуют колебания машины в продольно-вертикальной плоскости.

Ключевые слова: сахарная свекла, уборка ботвы, трактор, колебания, дифференциальные уравнения.

REFERENCES

1. *Khvostov VA, Reingart ES.* Machines for harvesting root crops and onions (theory, design, calculation). Moscow, VISKHOM. 1995;391 p.
2. *Pogorelyi LV, Tatyanko NV, Brey VV.* Beet harvesting machines (design and calculation). Ed. L.V. Pogorelyi. Kyiv, Tekhnika. 1983;168 p.
3. *Bulgakov VM.* Beetroot harvesters. Kyiv, Agrarna nauka. 2011;352 p.
4. *Khelemendyk MM.* Directions and methods to develop new working tools of farm machinery. Kyiv, Ahrarna nauka. 2001;280 p.
5. *Vasilenko PM.* Introduction to agricultural mechanics. Kyiv, Silhosposvita. 1996; 251 p.
6. *Kolychev YeI, Pereltsvayg IM.* About selecting the estimated influence on the research of smooth functioning of tractors and agricultural machinery. *Traktory i selkhoz mashiny.* 1976;(3):9–11.
7. *Chudakov DA.* Fundamentals of the theory and calculation of a tractor and car. Moscow, Kolos. 1972;384 p.
8. *Vasilenko PM.* The equations of dynamics of systems with nonholonomic constraints. *Zemledelcheskaya mekhanika: Proc. Moscow, Mashinostroeniye.* 1968;Vol. 2:26–34.
9. *Butenin NV, Lunts YaL, Merkin DR.* Course of theoretical mechanics: a textbook for high schools. Moscow, Nauka. 1985;Vol. 2: 496 p.
10. *Morozov BI, Gringauz NM.* Calculation of a wheeled vehicle movement on rough roads. *Mekhanizatsiya i elektrifikatsiya sotsialisticheskogo selskogo khoziaystva.* 1969;(7):11–14.
11. *Reznik NE.* Theory of cutting with a blade and fundamentals of calculations for cutting apparatus. Moscow, Mashinostroeniye. 1975;311 p.
12. *Bosoy EC.* Cutting apparatus of harvesters. Theory and calculation. Moscow, Mashinostroeniye. 1967;167 p.
13. *Tatyanko NV.* Calculation of working tools for cutting of sugar beet leaves. *Traktory i selkhoz mashiny.* 1962; (11):18–21.